



Model 6360-1001

SELF-PRIMING PUMP

FEATURES

- Motor:** Permanent magnet type, fully enclosed, stainless steel shaft.
- Dimensions:** 3" (76mm) high, 6-3/8" (162mm) long, 4-3/4" (120mm) wide
- Weight:** 4-1/2 lb (2 kg) (approx.)
- Body:** Bronze
- Impeller:** Jabsco Neoprene compound
- Seal:** Lip type
- Ports:** 1/2" Internal Pipe Threads
1" External Hose Barb
Adaptor for 3/4" External Garden Hose Thread

Motor meets USCG Electrical Standards (Title 33, Chapter I, Part 183, Subpart I) for IGNITION PROTECTION on gasoline powered vessels.

APPLICATION

Use for bilge pumping, livewell circulation, washdown and general pumping requirements. If bilge water contains significant amount of oil, the standard impeller should be replaced with impeller No. 6303-0003, which is an oil-resistant nitrile material.

With a wet impeller, pump will produce a suction lift of about 4 feet (1.2m) and a lift to 20 feet (6m) when primed. BE SURE SUCTION LINES ARE AIRTIGHT.

WARNING Explosion hazard. Do not operate with rivets removed from motor case. Explosion resulting in personal injury, death or property damage can occur. Case openings must be sealed to avoid explosion and maintain ignition protected rating.



WARNING Explosion hazard. Do not pump gasoline, solvents, thinners or other flammable liquids. To do so can cause an explosion resulting in injury or death.



INSTALLATION

The pump must be mounted in a dry location – the motor is not waterproof and must not be submerged. **SELECTION OF A COOL, VENTILATED** location will generally extend pump motor life. The unit can be mounted in any desired position. It is best to mount so that water dripping from loose port connection will not wet the motor. The pump head may be rotated 1800 degrees on the motor to change direction of flow.

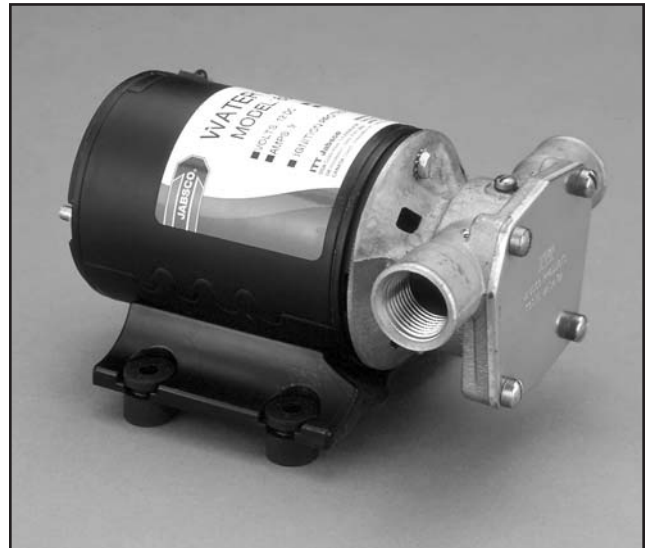

Model 6360-1001

MODEL AVAILABLE

Model	Voltage DC	AMP Draw	Fuse Size
6360-1001	12	8*	15

* Nominal amp draw at 10 psi.

OPERATION

Flexible impeller pumps must *NOT* be run dry, as the pumped liquid is the lubricant for the impeller. Observe the outlet and shut off pump as soon as liquid stops flowing. An automatic level switch is convenient to control the pump.

The pump cannot run against a closed outlet such as encountered when using a garden hose type shut-off nozzle.

Pressure for normal operation should not exceed 20 feet of head (8.7 psi).

Temperature of pumped liquid may be in the range of 450 - 1800F (70 - 820C).

WARNING Motor runs hot—about 180° is a normal temperature. Prolonged contact during operation may cause a burn.



PLUMBING CONNECTIONS

Pump ports have external 1" hose barb and internal 1/2" pipe threads. Also provided are two male port adaptors to allow the attachment of 3/4" female garden hose fittings. Use hose that does not kink when bent and with sufficient wall thickness to prevent collapse when used on suction side of pump. Hoses should be routed so that some water will be retained in pump body to wet the impeller. Wetting the impeller aids in priming and extends impeller life. Use a strainer on the intake hose to stop trash and solids from going through the pump. All hoses must have air tight connections to enable faster priming.

⚠ WARNING



Explosion hazard. If pump is operated in an area containing flammable vapors, wire leads must be joined by insulated mechanical locking connectors. Loose or inadequate wire connections can spark resulting in an explosion. Property damage, injury or death can occur.

ELECTRICAL CONNECTIONS

Connect black wire to negative (-) terminal of battery. The orange wire should run to a fused overload protected switch or circuit breaker with a 15 amp rating, with a wire from switch or breaker to positive (+) terminal of battery. Electrical circuit must be independent of all other accessories. Failure to connect black wire to negative and orange wire to positive will result in backwards motor rotation and possible motor and pump damage. Correct motor rotation is clockwise looking at shaft end of motor. Use proper wire size as determined by wire table elsewhere on this sheet. Should the fuse blow, replace with the same size fuse after determining reason for blown fuse.

HEAD-FLOW CHART

P.S.I.	Total Head		Capacity	
	Feet	Meters	GPM	L/Min.
2.1	5	1,5	6.3	23,8
4.3	10	3,0	5.4	20,4
6.5	15	4,6	4.2	15,9
8.7	20	6,1	2.8	10,6

Table shows approximate Head-Flow for new pump.

MINIMUM WIRE SIZES

Wire Length Between Battery and Motor	12V
1-10 ft (3m)	#12
11-20 ft (6m)	#10
21-30 ft (9m)	#8

WIRING DIAGRAM

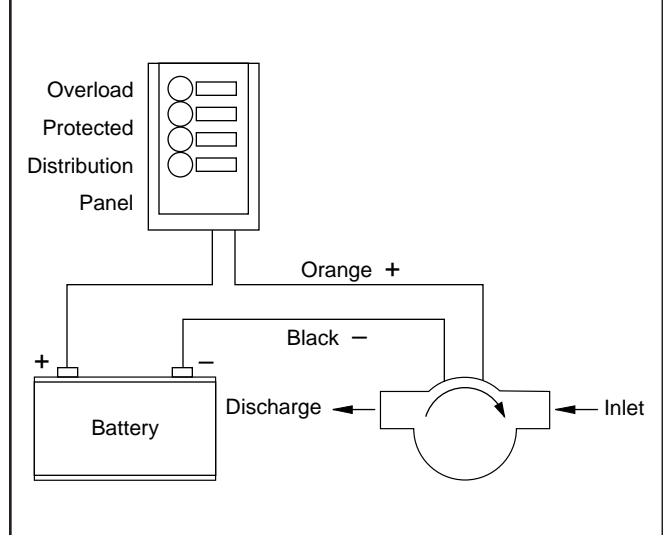

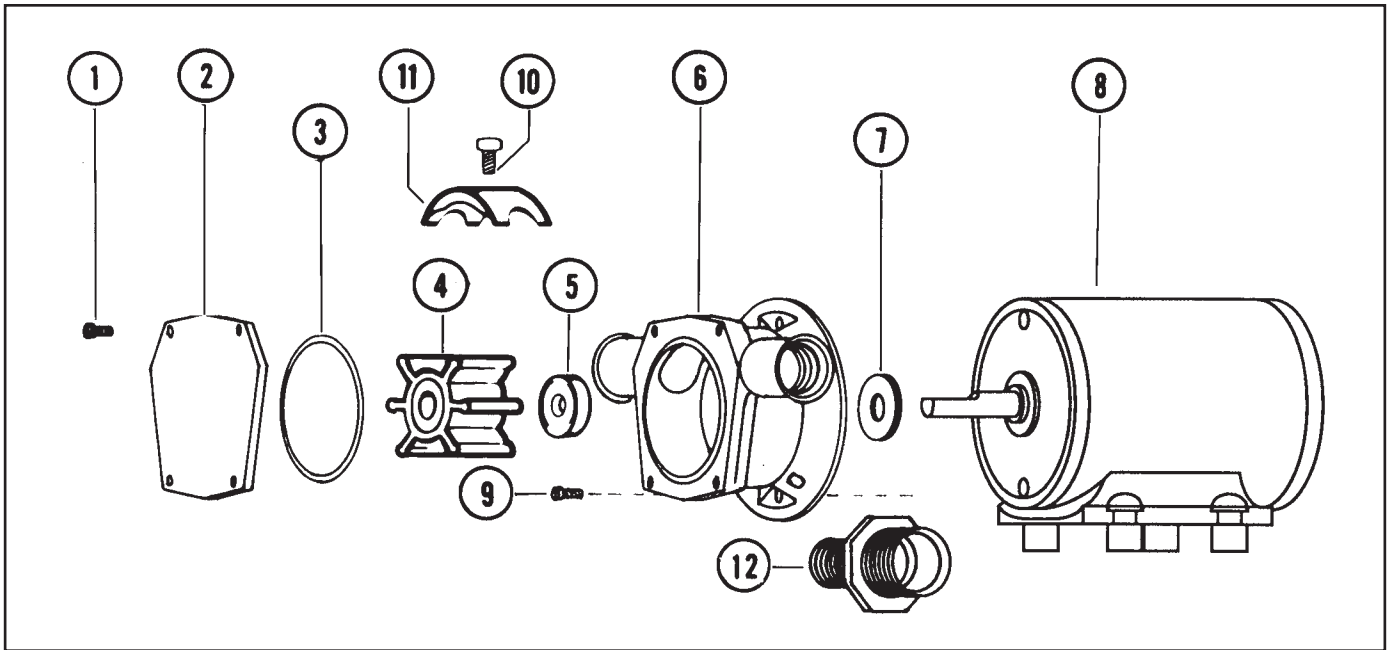

KEY	PART NUMBER	DESCRIPTION	QTY. REQ.
1	18753-0102	Screw Kit (4 each)	1
2	6791-1100	End Cover	1
3	18753-0104	*O-Ring	1
4	6303-0001	*Impeller	1
5	93000-0100	*Seal	1
6	18649-1100	Body †	1
7	6342-0000	Slinger	1
8		Motor	1
	98012-0020	Model 6360-1001 12V **	
9	98019-0020	Screw (Pump to motor)	2
10	91002-0010	Screw (Cam)	1
11	2907-0000	Cam	1
12	18753-0103	Port Adaptor Kit (2 each)	1
	90061-0001	Service Kit	
	7440-1001	Replacement Pump Head	

* Part Contained in Service Kit.

† When replacing a pump body that uses a round end cover (3 hole pattern) it is necessary to replace the end cover, screws and replace the gasket with an O-Ring (order keys # 1, 2 & 3).

** For 24V and 32V replacement motors, consult the factory.

6303-0003 Oil resistant "Nitrile" Impeller available separately.

DISASSEMBLY

1. Remove end cover screws, end cover and O-ring.
2. Withdraw impeller.
3. Remove cam screw and cam (cam removal is not required for seal and impeller service).
4. Loosen and remove two slotted hex screws, which attach body to motor.
5. Tap body lightly between ports and remove body from motor.
6. Deform seal and remove from body cavity.

NOTE: Do not tamper with or disassemble motor.

MAINTENANCE

Check wires and connections to be sure corrosion is not adding additional resistance to the motor circuit and causing a low voltage condition **at the motor. Low voltage can inhibit motor from starting and cause fuse to blow.** Full voltage should be available to prevent motor damage.

NOTICE: If pump is idle for extended periods, the impeller may stick to the pump body, preventing motor rotation and causing blown fuses. To correct, remove end cover and impeller, clean body and impeller, then lubricate with water or small amounts of grease before assembly.

If pump is to be in freezing temperatures, drain by loosening end cover screws.

A Service Kit, or at least spare impellers, should be carried aboard to be assured of pumping capability.

ASSEMBLY

1. Lubricate seal. Deform seal and install in cavity with open side of seal facing impeller.
2. Lubricate motor shaft and install body on motor.
3. Apply small amount of sealant to top of cam and install cam in body.
4. Lubricate impeller bore and, aligning flat in impeller with flat on motor shaft, install impeller with clockwise rotary motion.
5. Install O-ring, end cover and screw.

**DIMENSIONAL
DRAWING Inches
(millimeters)**

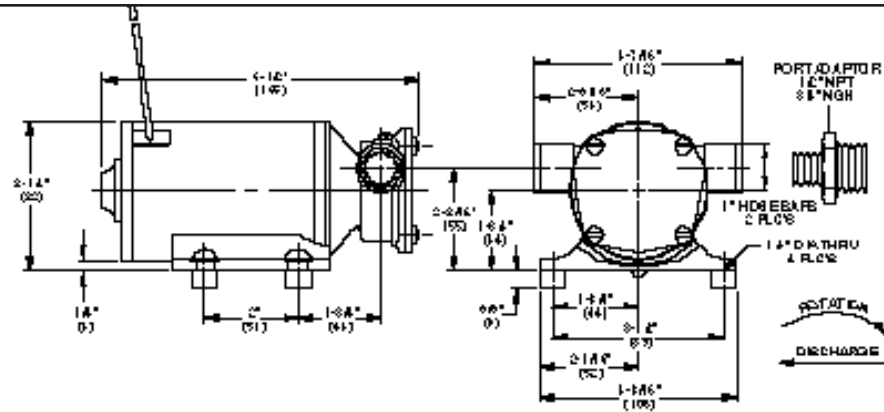

ONE YEAR LIMITED WARRANTY

A. LIMITED WARRANTY: ITT warrants that at the time of shipment, the products manufactured by ITT and sold hereunder shall be in conformity with applicable written specifications and descriptions referred to or set forth herein, free from defects in material and workmanship, merchantable, and suitable for a particular purpose, provided such is implied by State law under the circumstances of this sale.

B. WARRANTY ADJUSTMENT:

1. ITT agrees to repair or furnish a replacement for, but not to remove or install, any product or component thereof which, within one (1) year from date of purchase, shall upon test and examination by ITT prove defective within the above warranty. Receipt verifying purchase date is required to obtain adjustment.
2. Buyer shall notify ITT of any defect within this warranty no later than ninety (90) days after the defect is discovered.
3. No product will be accepted for return or replacement without the prior written authorization of ITT. Upon such authorization, and in accordance with instructions from ITT, the product will be returned to ITT, shipping charges prepaid by Buyer. Products returned to ITT will be addressed as follows:

JABSCO
1485 Dale Way
Costa Mesa, California 92626-3998

Or to such alternate locations as may be designated on the product, its container, or this sheet.

Repair or replacement made under this warranty will be shipped prepaid to Buyer.

C. EXCLUSIONS FROM WARRANTY AND LIMITATION OF LIABILITY:

1. The foregoing warranty is limited solely as set forth herein and applies only for the period designated above.

2. ITT SHALL NOT BE LIABLE FOR ANY LOSS, DAMAGE, SPECIAL OR CONSEQUENTIAL DAMAGE OF ANY KIND, WHETHER BASED UPON WARRANTY, CONTRACT, NEGLIGENCE, OR STRICT LIABILITY ARISING IN CONNECTION WITH THE SALE, USE, OR REPAIR OF THE PRODUCT.
3. THE MAXIMUM LIABILITY OF ITT IN CONNECTION WITH THIS WARRANTY SHALL NOT IN ANY CASE EXCEED THE CONTRACT PRICE FOR THE PRODUCT CLAIMED TO BE DEFECTIVE OR UNSUITABLE.
4. This warranty does not extend to any product manufactured by ITT which has been subjected to misuse, neglect, accident, improper installation, or use in violation of instructions furnished by ITT.
5. This warranty does not extend to or apply to any unit which has been repaired or altered at any place other than ITT's factory, or by persons not expressly approved by ITT, nor to any unit the serial number, model number, or identification of which has been removed, defaced or changed.
6. Components manufactured by any supplier other than ITT shall bear only that warranty made by the manufacturer of that product.
7. This warranty applies to products defined as "consumer products" by the Consumer Product Warranties Act as from time to time amended.

D. CONSUMER RIGHTS:

This warranty gives you specific legal rights, and you may have other rights which vary from state to state. Some states do not allow exclusion or limitation of damages.

STANDARD WARRANTY:

If the products manufactured and sold hereunder are not Consumer Products, the warranty extended to Buyer shall be as set forth in subparagraphs (A), (B), and (C), **EXCEPT THAT ALL EXPRESS OR IMPLIED WARRANTIES OR MERCHANTABILITY OR SUITABILITY FOR ANY PARTICULAR PURPOSE ARE EXCLUDED.**

Jabsco



THE PRODUCTS DESCRIBED HEREIN ARE SUBJECT TO THE JABSCO ONE YEAR LIMITED WARRANTY, WHICH IS AVAILABLE FOR YOUR INSPECTION UPON REQUEST.

U.S.A.
Jabsco
1485 Dale Way, P.O. Box 2158
Costa Mesa, CA 92628-2158
Tel: (714) 545-8251
Fax: (714) 957-0609

UNITED KINGDOM
Jabsco
Bingley Road, Hoddesdon
Hertfordshire EN11 0BU
Tel: +44 (0) 1992 450145
Fax: +44 (0) 1992 467132

CANADA
Fluid Products Canada
55 Royal Road
Guelph, Ontario N1H 1T1
Tel: (519) 821-1900
Fax: (519) 821-2569

JAPAN
NHK Jabsco Company Ltd.
3-21-10, Shin-Yokohama
Kohoku-Ku, Yokohama, 222
Tel: 045-4758906
Fax: 045-475-8908

GERMANY
Jabsco GmbH
Oststrasse 28
22844 Norderstedt
Tel: +49-40-53 53 73 -0
Fax: +49-40-53 53 73 -11