



Models 30510-4XXX 30510-2XXX

Models 30510-4XXX, 30510-2XXX

SELF-PRIMING PUMPS

FEATURES

- Pump Type:** 30510-4XXX Close Coupled
30510-2XXX Pump Head
- Body:** 316 Stainless Steel
- Impeller:** Neoprene, Nitrile and Viton*
- Shaft Seal:** Mechanical; Carbon-on-Ceramic or Tungsten Carbide; Nitrile or Viton.
- Ports:** 3/4" NPT Internal
- Shaft:** 316 Stainless Steel
- Motor:** 115 Vac, Single Phase, 60Hz, 3/4 HP, 1750 RPM, TEFC, C-Face, 56C Frame, Overload Protected, Capacitor Start.
- Weight:** 30510-4XXX 36.0 lbs (16,3 kg) Approx.
30510-2XXX 7.5 lbs (3,4 kg) Approx.

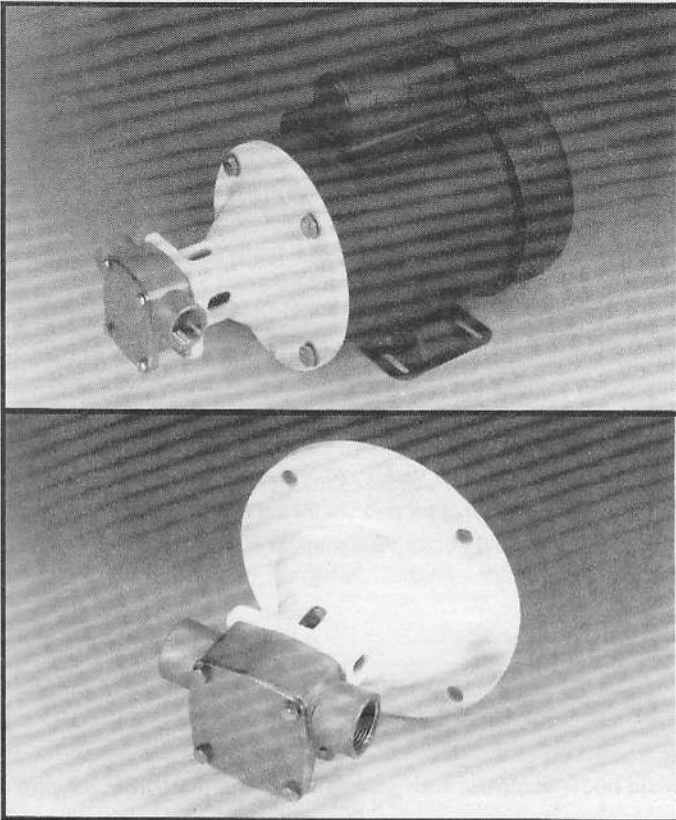

⚠ MOTOR WARNING

MOTOR CAN SPARK. EXPLOSION & DEATH CAN OCCUR.
DO NOT USE WHERE FLAMMABLE VAPORS ARE PRESENT.

APPLICATIONS

INDUSTRIAL: Circulating and transferring, velocity-mixing, pumping machine tool coolants, spill return, sump drainage, chemicals, pharmaceuticals, soap, liquors, ink, dyes, alcohol, dilute acids, tanning liquors, glycerine, brine, etc.

PHARMACEUTICAL: Processing medicines, lotions and preparations. Filtering pharmaceutical solutions. Filling line supply pump.

PAPER PROCESSING: Transferring and applying starches, sizes, etc. Circulating and processing wood pulp slurries.

FOOD, BEVERAGE & DAIRY: Transfer brines, vinegar, syrups during processing, liquids containing solids in suspension such as chopped tomatoes, nuts, etc. Removal or distillery wort and brewery slop. Processing viscous materials such as peanut butter, mayonnaise, ketchup, honey, etc. (low speed). Pumping whiskey, wine, rums, juices and ciders.

WARNING: Do not pump flammable liquids as explosion may result causing property damage, severe personal injury or death.

VARIATIONS AVAILABLE

MODEL	DESCRIPTION
30510-4001 30510-2001	Standard Pressure, Neoprene Impeller, Carbon Seal
30510-4003 30510-2003	Standard Pressure, Nitrile Impeller, Carbon Seal
30510-4004 30510-2004	Standard Pressure, Viton Impeller, Carbon Seal
30510-4101 30510-2101	Standard Pressure, Neoprene Impeller, Tungsten Carbide Seal
30510-4103 30510-2103	Standard Pressure, Nitrile Impeller, Tungsten Carbide Seal
30510-4104 30510-2104	Standard Pressure, Viton Impeller, Tungsten Carbide Seal

Viton * is a trademark of E.I. Du Pont de Nemours and Company.

OPERATING INSTRUCTIONS

- INSTALLATION** – Pump may be installed in any position. The rotation of the pump shaft determines the location of the pump's intake and discharge ports. Refer to dimensional drawing. Pump is normally assembled at factory for clockwise rotation (looking at end cover). If counter clockwise rotation is desired, follow steps 1 and 2 of disassembly and step 7 of assembly instructions to change direction of impeller blade deflection under cam.
- MOTOR SELECTION** – Pump head is designed to fit a 56C Frame NEMA C-Face motor. Motor should be rated 3/4 horsepower at 1750 RPM with a service factor of one. Due to high bearing loads, motor should be ball bearing equipped with the front bearing locked against axial movement. Motor should be capacitor start and foot mounted.
- SPEEDS** – 100 RPM to the maximum shown in the performance curves. For longer pump life, operate at lowest possible speeds. Lower speeds are required for viscous liquids. Consult the factory for proper speeds and H.P. requirements.
- SELF-PRIMING** – Primes at low or high speeds. For vertical dry suction lift of 10 feet, a minimum of 800 RPM is required. Pump will produce suction lift to 22 feet when wet.
BE SURE SUCTION LINES ARE AIRTIGHT OR PUMP WILL NOT SELF-PRIME.
- DISCHARGE** – When transferring liquids further than 25', use one size larger discharge line than discharge port size.
- RUNNING DRY** – Unit depends on liquid pumped for lubrication. DO NOT RUN DRY for more than 30 seconds. Lack of liquid will damage the impeller and seal.
- CHEMICAL COMPATIBILITY** – Consult the Chemical Resistance Guide in the JABSCO Industrial Pump Catalog (available upon request from ITT Jabsco) or the factory for proper body materials and impeller compounds. If corrosive fluids are handled, pump life will be prolonged if pump is flushed with a neutralizing solution after each use or after each work day. A Tungsten Carbide Seal variation is available for pumping liquids that contain abrasives or are highly corrosive.
- PRESSURES** – Consult Performance Curve for maximum recommended pressure for pumps in continuous operation. If pressures exceed these shown, consult the factory.
- TEMPERATURE** – The operating temperature limits of the pump depends on the impeller compound. The following ranges apply: Neoprene impeller - 45° to 180° F (7° to 82° C), Nitrile - 50° to 180° F (10° to 82° C), Viton - 60° to 180° F (15° to 82° C).
- IMPELLER TORQUE** – The torque required to initiate rotation of a new impeller in a dry pump body is:
Standard Pressure Impeller (14281-Series):
Forward = 1.5 pounds force - feet
Reverse = 4.3 pounds force - feet
These values may vary slightly due to impeller compounding, blade set, and body material of construction. Consult factory for more information.
- SPARE PARTS** – To avoid costly shutdowns, keep a spare JABSCO impeller, seal and O-ring set on hand.

SERVICE INSTRUCTIONS

DISASSEMBLY

- Remove the four end cover screws. Remove end cover and O-ring.
- Remove the four screws holding the body to the adapter flange. Slide body, complete with impeller and wearplate from adapter and shaft.
- Remove mechanical seal by inserting two screwdrivers behind seal collar, and gently lever collar and seal assembly forward on shaft. Use extreme care not to mar shaft. Remove seal seat and rubber cup from recess in wearplate.
- Remove the four screws holding the adapter to the motor and remove the adapter.
- Stub shaft is held in place with set screws and Loctite* RC/680 retaining compound. Extreme care must be taken not to damage the motor shaft and bearings when removing the stub shaft. Heat shaft joint area to facilitate disassembly of set screws and stub shaft from motor shaft. DO NOT EXCEED 350°F when heating joint area. Once joint area has been heated, remove set screws and slide stub shaft from motor shaft.

ASSEMBLY

- Liberal apply Loctite RC/680 retaining compound to the motor shaft and slide the stub shaft on, positioning the base of the stub shaft 0.37" from the bolt mounting surface of motor. For clarification refer to Figure 1 below. Loctite aids in preventing fretting and subsequent shaft failure. Apply Loctite to the four set screws and torque to 85-90 in. lbs. Wipe off excess Loctite.
- Replace the adapter to the motor and tighten the four mounting screws to 20 ft. lbs.
- Replace mechanical seal by sliding spacer onto shaft up to locating shoulder, then smear shaft with light lubricating oil. Push on seal gently until it engages with spacer. Fit rubber cup and seal seat into wearplate.
- Insert impeller in pump body, fit O-ring in each end of the pump body.
- Slide wearplate and body assembly over shaft, position wearplate in housing. Fit body to adapter with screws. Torque screws to 20 in. lbs.
NOTE: A gap should be maintained between adapter and body.
DO NOT overtighten screws.
- Fit end cover and end cover screws. Torque screws to 20 in. lbs.
- Changing Pump Rotation (looking at end cover):
 - Clockwise Rotation: Insert impeller into pump body with blades bending counterclockwise.
 - Counterclockwise Rotation: Insert impeller into pump body with blades bending clockwise.

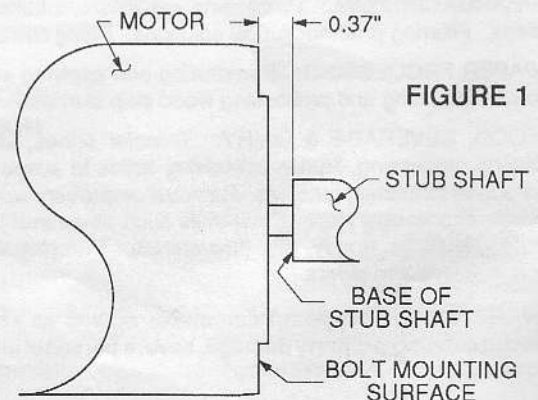

FIGURE 1

Loctite* is a trademark of Loctite Corporation.

For technical advice or service please take your pump into your local pump service center.
To order pump or parts or for pricing please go to the following links :

[Jabsco Pumps Home >>](#)

[Jabsco Pumps stock list >>](#)