



## Model 31670-Series

### Dual Max 7.5 GPM (28 LPM)

AUTOMATIC TWO STAGE WATER SYSTEM WITH ACCUMULATOR TANK AND PUMPGARD STRAINER

**IDEAL FOR PLEASURE AND COMMERCIAL BOATS WITH HIGH DEMAND REQUIREMENTS**

#### FEATURES

- Self-Priming
- Run Dry Ability
- Smooth Flow
- Low Amp Draw
- Two Stage Operation
- Easy Installation
- Internal Bladder Accumulator Tank
- Meets USCG 183.410 and ISO 8846 MARINE for Ignition Protection
- **CE**

#### SPECIFICATIONS

<b>Pump Body</b>	Glass Filled Polypropylene
<b>Pump Design</b>	Multi-Chamber Diaphragm
<b>Suction Lift</b>	Self-Priming to 5 ft. (1.5 m)
<b>Ports</b>	3/4" Hose
<b>Motor</b>	Permanent Magnet Type with Thermal Overload Protection
<b>Accumulator</b>	Hygienic, impact and pressure resistant Plastic Construction. 33 fl. oz (1 Liter) capacity
<b>Shipping Weight</b>	15 lb (6.8 kg) approx.

#### APPLICATIONS

The Dual Max Automatic Water System is designed for boats and RV's with multiple outlet water systems. The system operates automatically. When a faucet is opened, the system instantly begins operation to provide a smooth constant flow from tank to faucet. Closing the faucet automatically discontinues system operation.



Model 31670-Series

The accumulator tank smooths water flow and reduces on/off cycling of the pump by lessening the variation in pressure. Even flow of water gives better control of hot water temperature especially noticeable with instantaneous gas water heaters and showers. Reduced on/off cycling reduces noise from the pump, water hammer and gives longer pump life.

#### VERSATILE TWO STAGE SYSTEM

- Under low demand conditions only the primary pump operates delivering up to 3.8 gpm. Amp draw is well below that of other high flow systems under the same conditions.
- Accumulator tank capacity is perfectly matched to the primary pump. An additional large accumulator is not required.
- Under high demand the secondary pump is activated. and flow increases. Under maximum demand total current draw is only 15 amps (12v) or 7.5 amps (24v).
- The dual pump configuration offers increased reliability. Should either of the system pumps become inoperable for any reason, the remaining pump will continue to function with the capability to supply several outlets.

Models	Gpm (Lpm)	Voltage	Nominal psi (bar)		Max Amp Draw	Pump Fuse†	Breaker††
			Cut-In	Cut-Out			
31670-0092	7.5/28.4	12 Vdc	20 (1.4)	40 (2.8)	15	10	20
31670-0094	7.5/28.4	24 Vdc	20 (1.4)	40 (2.8)	7.5	10	10

† Each of the two pumps is supplied prewired with an automotive type fuse. These fuse/holders must remain in place to isolate the pumps from each other and allow the remaining pump to operate should one fail.

†† Customer supplied, not included with pump.

**⚠ WARNING**  **Explosion hazard. Do not pump gasoline, solvents, thinners or other flammable liquids. To do so can cause an explosion resulting in injury or death.**

**INSTALLATION**

**MOUNTING**

The Dual Max system is self-priming and may be located above or below the fresh water tank in a dry location.

**PLUMBING**

If the system has rigid piping, provide a short length of hose between pipe and the pump to avoid noise and vibration. Use stainless steel clamps at both ends of hose. NOTE: Inlet and outlet hose must be minimum 3/4" (19 mm) ID reinforced hose. Branch lines to outlets should be no smaller than 3/8" (10 mm). Two inlet strainers have been installed in the Dual Max system to keep debris out of system. Fresh water tank must be vented.

If the system includes a city water inlet, an inlet pressure regulator which reduces pressure to 40 psi or less is required. The Jabsco 44410 Series is recommended. Avoid any kinks or fittings which could cause excessive restrictions. Remember to periodically clean faucet and

**⚠ WARNING**  **Fire hazard. Wiring must comply with applicable electrical standards and include a properly sized fuse or circuit breaker. Improper wiring can cause a fire resulting in injury or death.**

Pumpgard screen.

**WIRING**

The Dual Max system should be wired to the power supply through a switch rated for 20 amps (12v) or 10 amps (24v). Turn the system off when not in use for extended periods or when tank is out of water.

The electrical circuit should be protected with an over-current protection device in the positive lead. See chart for proper size breaker. Pump circuit should not include any other electrical loads. Orange wire is positive. Black wire is negative.

Select wire size from the following chart. Use total length of wire from electrical source to pump **and** return. Chart allows for 3% voltage drop. If in doubt, use next larger wire size.

Total wire length	0-20 ft (0-6 m)	21-30 ft (6-9 m)	31-40 ft (9-12 m)	41-60 ft (12-18 m)
12 volt	#10 AWG (6 mm <sup>2</sup> )	#8 AWG (10 mm <sup>2</sup> )	#6 AWG (16 mm <sup>2</sup> )	#4 AWG (25 mm <sup>2</sup> )
24 volt	#16 AWG (1.5 mm <sup>2</sup> )	#14 AWG (2.5 mm <sup>2</sup> )	#12 AWG (4 mm <sup>2</sup> )	#10 AWG (6 mm <sup>2</sup> )

**If you are not familiar with applicable electrical standards, have the unit installed by a qualified electrician.**

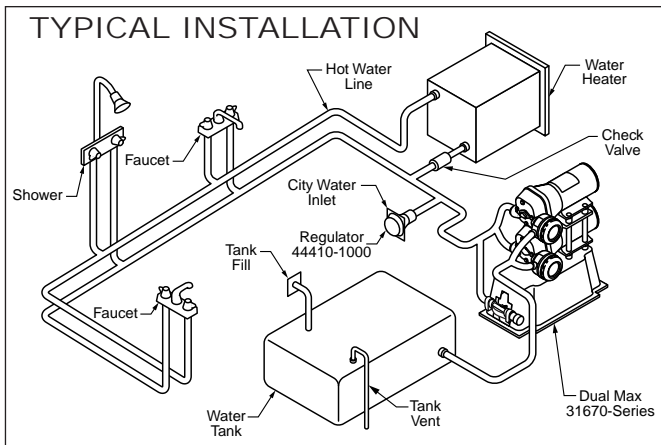

NOTE: Outlet is now front facing. Plumb tank to dual inlet strainers. Strainers maybe unplugged from pumps and reversed.

After installation, check the voltage at the pump motor. Voltage should be checked when pump is operating along with all the inside electrical fixtures. Full voltage must be available at the pump motor at all times.

**⚠ CAUTION** **Motor case will get hot. Prolonged contact during operation may cause a burn.**

**OPERATION**

1. Check level of water in tank.
2. Open all faucets hot and cold.
3. Switch pump on and wait for hot water tank and water lines to fill.
4. Close each faucet as flow becomes steady and free of air, close cold water faucet first. Pump should shut off soon after closing last faucet.
5. Pump is now ready for automatic operation. It will start when faucet is opened and stop when faucet is closed.
6. If pump will be inoperative for a considerable length of time, turn off circuit to pump and bleed pressure from system by opening faucets.

**ACCUMULATOR TANK PRESSURE**

Accumulator tank pre-charge air pressure should be checked annually. Turn pump circuit off. Open a faucet and relieve all system water pressure. Adjust pre-charge air pressure using an ordinary tire pressure gauge and tire pump. Air inlet valve is located on the end of the accumulator tank. Tank pre-charge pressure should be 10 psi. Close faucet and turn pump power on.

**⚠ CAUTION** **Do not overpressure tank. Pressures over 125 psi (8.6 bar) may rupture tank and cause personal injury.**

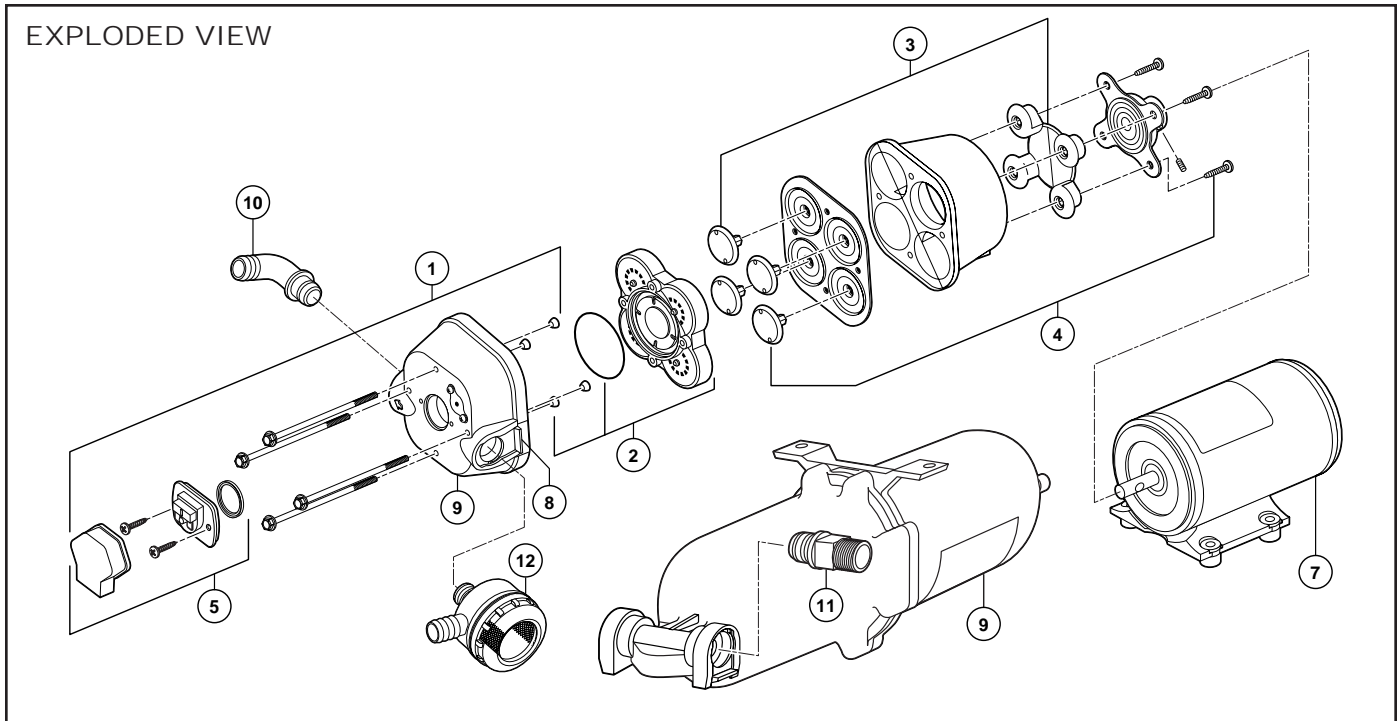

PARTS LIST

Key	Description	Qty.	31670-0092 (12V)	31670-0094 (24V)
1	Upper Housing 40 PSI	1	18910-4040	18910-4040
	Lower Housing 25 PSI	1	18753-0724	18753-0724
2	Valve Kit	1	18911-7030	18911-7030
3	Diaphragm Kit	1	18912-3040	18912-3040
4	Lower Housing Kit	1	18915-9002	18915-9002
5	Pressure Switch – Upper Pump 40 PSI	1	18916-0040	18916-0040
	Pressure Switch – Lower Pump 25 PSI	1	18916-0025	18916-0025
2,3,4,8	Service Kit	1	18920-9043	18920-9043
7	Motor Kit – Upper and Lower Pump	2	18753-0721	18753-0721
8	Slide Clips	4	18753-0722	18753-0722
9	Accumulator	1	30573-0000	30573-0000
10	Port Kit, 3/4' Elbow	4	30642-1000	30642-1000
11	Port Kit, 1/2' NPT(M)	2	30649-1000	30649-1000
12	Strainer	2	18753-0723	18753-0723
	Pumphead, Complete – Upper Pump 40 PSI	1	18914-6340	18914-6340
	Pumphead, Complete – Lower Pump 25 PSI	1	18914-6225	18914-6225

\* When replacing upper pump it is necessary to remove Body (3), rotate 180° and reassemble then remove Pressure Switch Body (2), rotate 180° and reassemble.

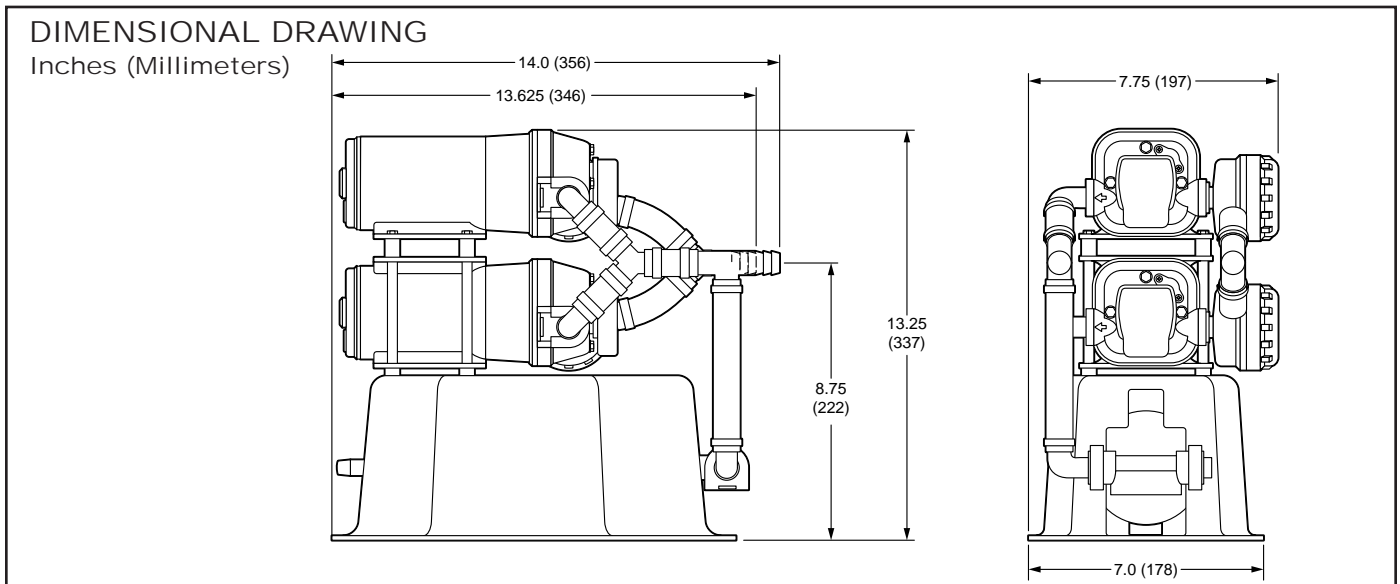

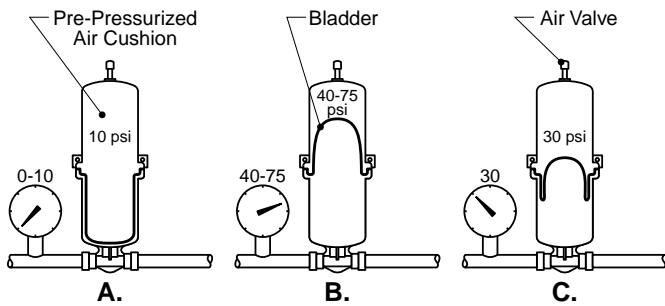

### SAFETY RELIEF VALVE RECOMMENDED

It is recommended that a relief valve with a setting of no more than 125 psi be installed. Often a relief valve is already installed at the water heater. Check its setting. This will protect the system in case the pressure switch fails.

### HOW THE PRESSURE ACCUMULATOR WORKS

- Factory installed precharged air cushion.
- When pump starts, water enters the reservoir. At maximum pressure, system is filled. Pump shuts off.
- When water is demanded, pressure in the air chamber forces water into the system. Pump stays off until minimum pressure is reached. Then pump turns on.

**CAUTION** Do not overpressure tank. Pressures over 125 psi (8.6 bar) may rupture tank and cause personal injury.

### TROUBLESHOOTING

#### PULSATING FLOW - PUMP CYCLES ON AND OFF

- Leaking water fixture or faucet
- Accumulator tank has no pre-charge air pressure
- Restricted water filter or pipe

#### MOTOR FAILS TO TURN ON

- Pump circuit has no power
- Blown fuse/Thermal Protector tripped
- Loose wiring connection
- Pressure switch failure
- Defective motor

#### MOTOR OPERATES BUT NO PUMP DISCHARGE

- Debris in check valve assembly
- Restricted intake or discharge line
- Air leak in intake line
- Punctured pump diaphragm

#### PUMP FAILS TO TURN OFF AFTER ALL FIXTURES ARE CLOSED.

- Empty water tank
- Punctured pump diaphragm
- Discharge line leak
- Defective pressure switch
- Insufficient voltage to pump
- Debris under flapper valves

#### LOW FLOW AND PRESSURE

- Debris in check valve assembly
- Air leak at pump intake
- Defective motor

**CAUTION** Motor has thermal overload protection. Motor will automatically shut off if temperature rises due to an overload condition. If the motor shuts off in this manner, close all faucets and valves. Pump will automatically re-start when motor cools.

### WINTERIZING YOUR WATER SYSTEM

Follow these steps to remove all water from your water system:

- Drain water by opening tank drain, or open a fixture to allow pump to operate until tank is dry.
- Open the lowest outlet in water system to drain lines.
- To remove any remaining water (about a cup), remove outlet hose on pump and activate pump. To blow out lines, attach air nozzle where outlet hose was removed. Make sure all fixtures are open before starting.
- Your water system is now winterized. Don't forget to reattach the outlet hose and close all fixtures.

**CAUTION** Do not use automotive type anti-freeze. It is poisonous. Use of this type anti-freeze will cause serious internal injury or death.

Jabco



U.S.A.  
Jabco  
20 Icon  
Foothill Ranch, CA 92610-3000  
Tel: 949.609.5106  
Fax: 949.859.1254

UNITED KINGDOM  
Jabco  
Bingley Road, Hoddesdon  
Hertfordshire EN11 OBU  
Tel: +44 (0) 1992 450145  
Fax: +44 (0) 1992 467132

CANADA  
Fluid Products Canada  
55 Royal Road  
Guelph, Ontario N1H 1T1  
Tel: (519) 821.1900  
Fax: (519) 821.2569

JAPAN  
NHK Jabco Company Ltd.  
3-21-10, Shin-Yokohama  
Kohoku-Ku, Yokohama, 222  
Tel: 045.475.8906  
Fax: 045.475.8908

GERMANY  
Jabco GmbH  
Oststrasse 28  
22840 Norderstedt  
Tel: +49-40-53 53 73 -0  
Fax: +49-40-53 53 73 -11

THE PRODUCTS DESCRIBED HEREIN ARE SUBJECT TO THE JABSCO ONE YEAR LIMITED WARRANTY, WHICH IS AVAILABLE FOR YOUR INSPECTION UPON REQUEST.